

**Features**

- Interfaces AutoSafe panels BS-310, BS-320 or BC-320 to the AUTROFIELDBUS
- Short circuit detection/isolation technology.
- Rail mounted.
- Conforms to CE standards.

**Application / Description**

The AUTROFIELDBUS driver EAU-340 is a communication protocol converter between the AutoSafe IFG panel and the BSD-340 PowerLoop drivers. The EAU-340 provides a redundant field bus system with a ring loop topology.

The AutoSafe panels can have one AUTROFIELDBUS connected, and each AUTROFIELDBUS can host up to 31 bus units.

The AUTROFIELDBUS has short-circuit detection/isolation technology which ensures that only one BSD-340 PowerLoop driver will be lost in case of internal failure (short-circuit).

The ring loop topology ensures that no detectors/field units will be lost due to a single break or short circuit of the AUTROFIELDBUS cable.

The AUTROFIELDBUS cable is normally 2-wire twisted pair category 5 copper cable, however, fibre optic cable is possible by use of separate signal converters. The AUTROFIELDBUS uses the same guidelines as AUTROLON, in terms of cable lengths, fibre modem and boosters.

The EAU-340 is to be mounted in a subrack in the same rack as AutoSafe.

**Capacity / Limitation**

- Maximum one EAU-340 can be used for each panel.
- Maximum 31 AUTROFIELDBUS units can be connected to the AUTROFIELDBUS.

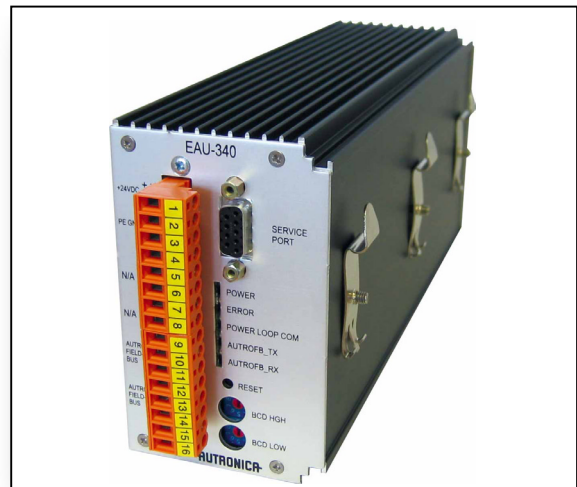

**Faults signalled by the EAU-340**

- AUTROFIELDBUS open loop
- AUTROFIELDBUS short-circuited loop
- Internal faults

**Technical Specifications**

<b>Weight</b>	600g
<b>Mounting</b>	DIN TS-35 rail mounted
<b>Relative Humidity</b>	10 - 95 % non-condensing
<b>Temperature</b>	-20 - +70 °C
<b>Shock / vibration</b>	DNV requirements for technical rooms anywhere onboard ships
<b>Degree of protection</b>	IP20
<b>Maintenance</b>	None
<b>Supply Voltage</b>	18 – 32 VDC
<b>Current Consumption</b>	200 mA at 24V DC
<b>Housing Material</b>	Aluminium front and PCB.
<b>Approvals</b>	EN54, DNV, CE

*Specification subject to change without notice.*



**Order Numbers**

Order number	Description
EAU-340	AUTROFIELDBUS Driver, Rail Mounted

**Dimensions / Connections**

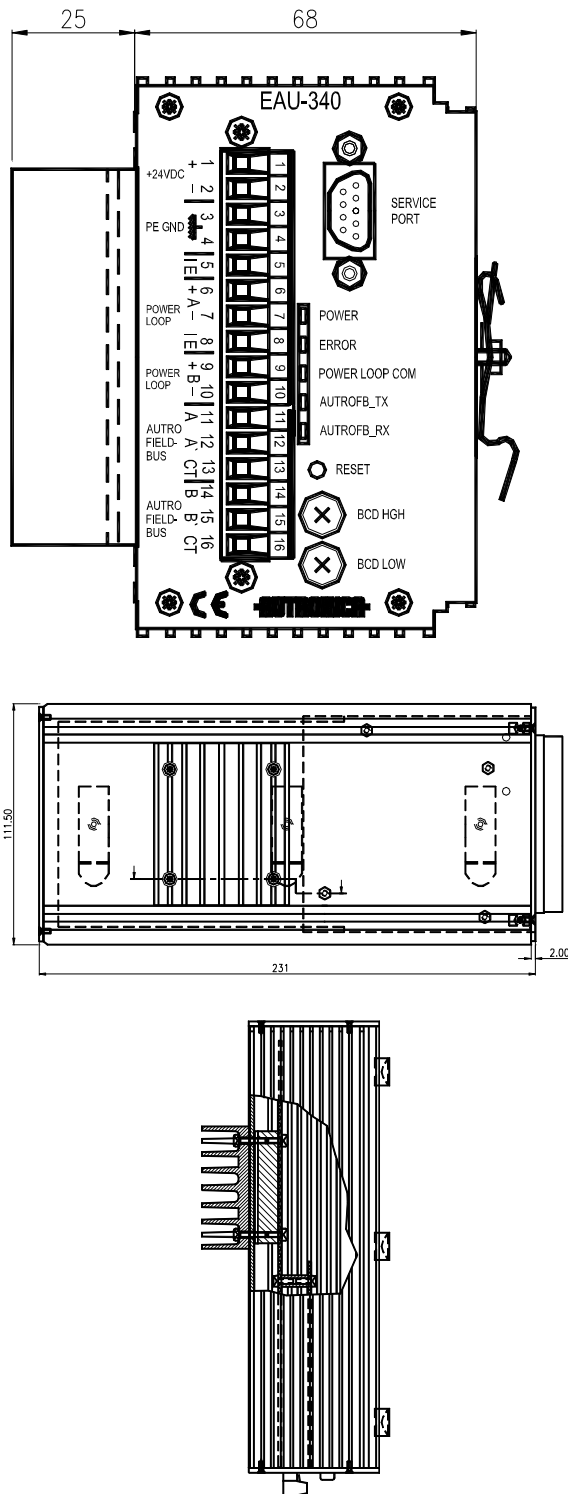

**Rotary Switch Setting**

The rotary switches must always be set to 00.

**Status LEDs**

The EAU-340 Status LEDs:

1. Green: Power indicator
2. Red: Error indicator
3. Yellow: PowerLoop traffic
4. Green: AUTROFIELDBUS TX
5. Red: AUTROFIELDBUS RX

**Termination**

The EAU-340 has a plug-in terminal block capable of 2.5mm<sup>2</sup> cables.

Screw Terminal no.	Signal
<b>Power Supply</b>	
1	+24V DC input
2	0V input
<b>Earthing</b>	
3	PE
4	PE
5	IE
<b>PowerLoop Interface</b>	
6	Not in use.
7	Not in use.
8	Not in use.
9	Not in use.
10	Not in use.
<b>AUTROFIELDBUS</b>	
11	AUTROFIELDBUS A1
12	AUTROFIELDBUS A2
13	AUTROFIELDBUS A shield (Floating)
14	AUTROFIELDBUS B1
15	AUTROFIELDBUS B2
16	AUTROFIELDBUS B shield (Floating)

**Overview**

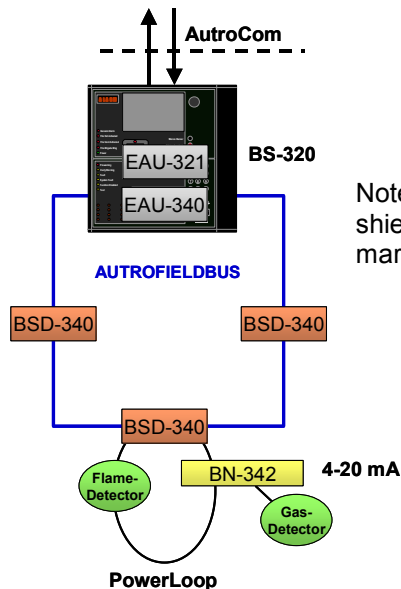

Note: All cables must be shielded in offshore and maritime applications.